

H (min.)	112	113	114	115	116	117	118	119	120	121	122	123	124	125	126	127	128	129	130
D (min.)	100	101	102	103	104	105	106	107	108	109	110	111	112	113	114	115	116	117	118
X	90	91	92	93	94	95	96	97	98	99	100	101	102	103	104	105	106	107	108

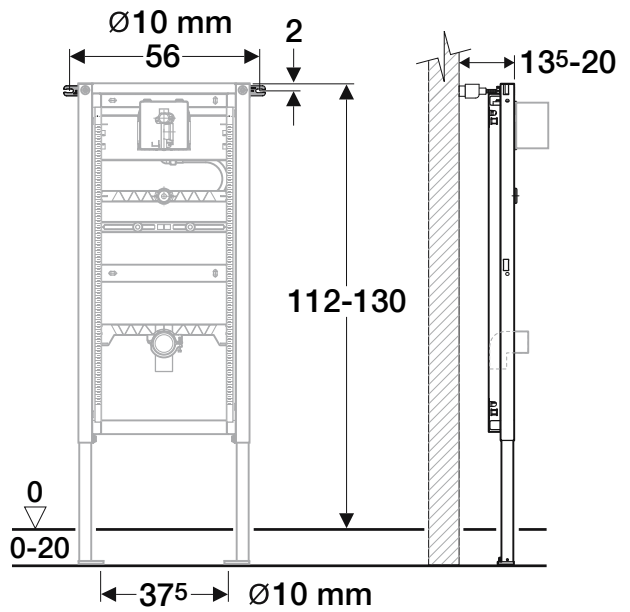

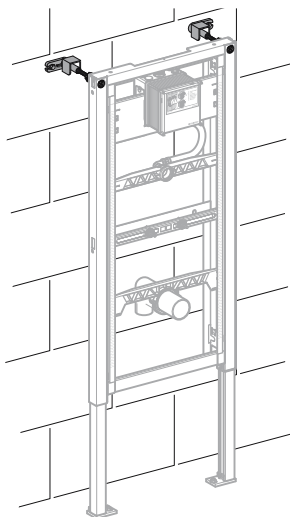

1

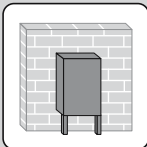
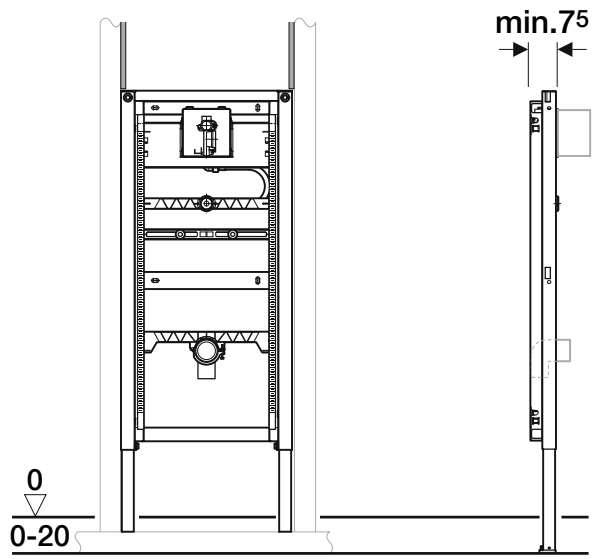
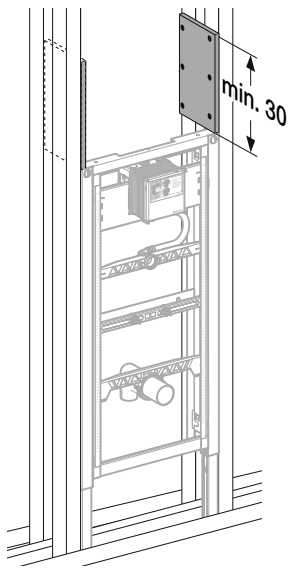
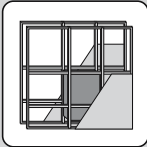
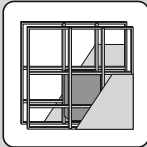
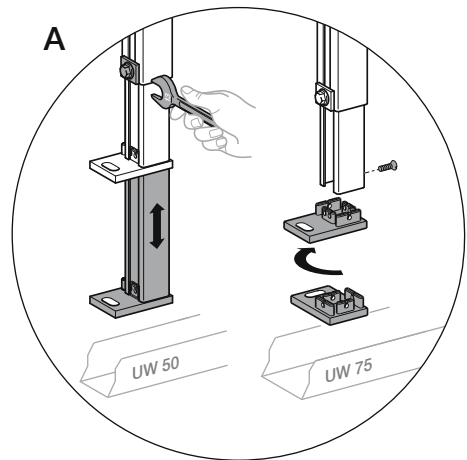
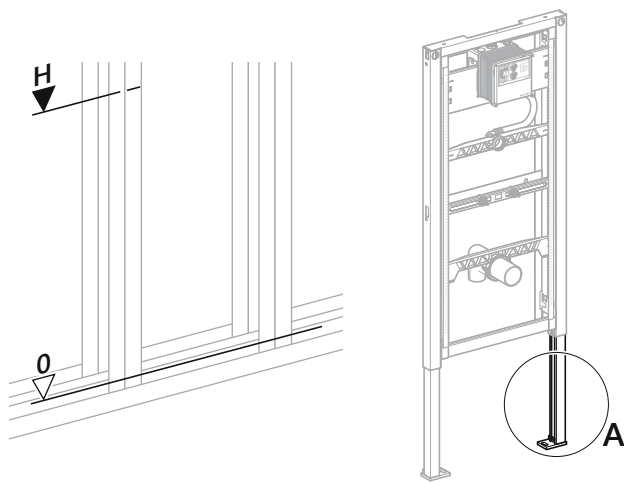

2

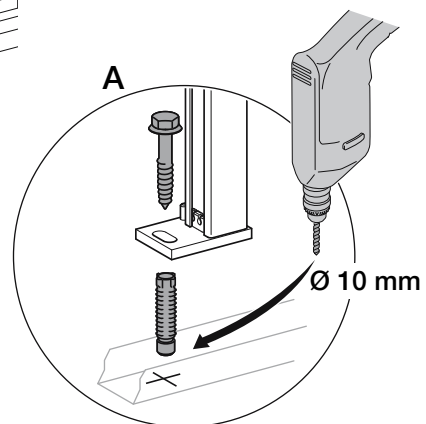
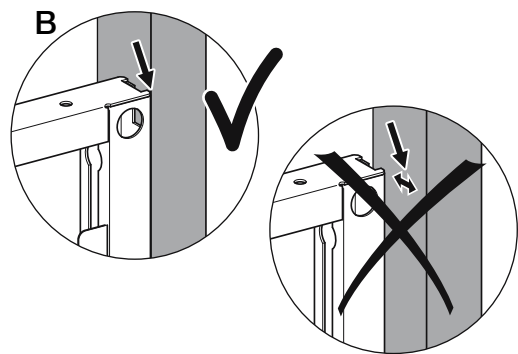
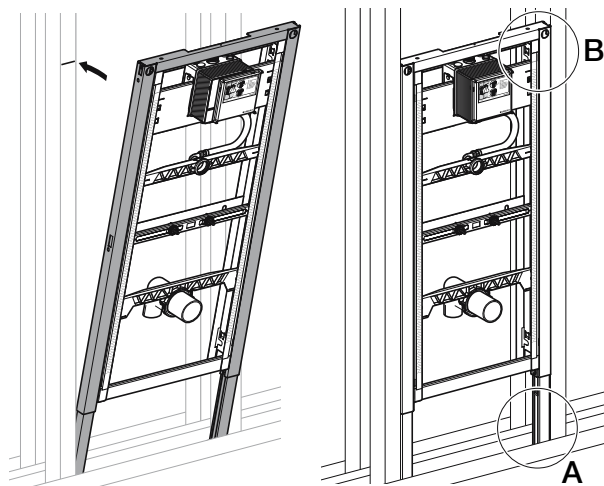

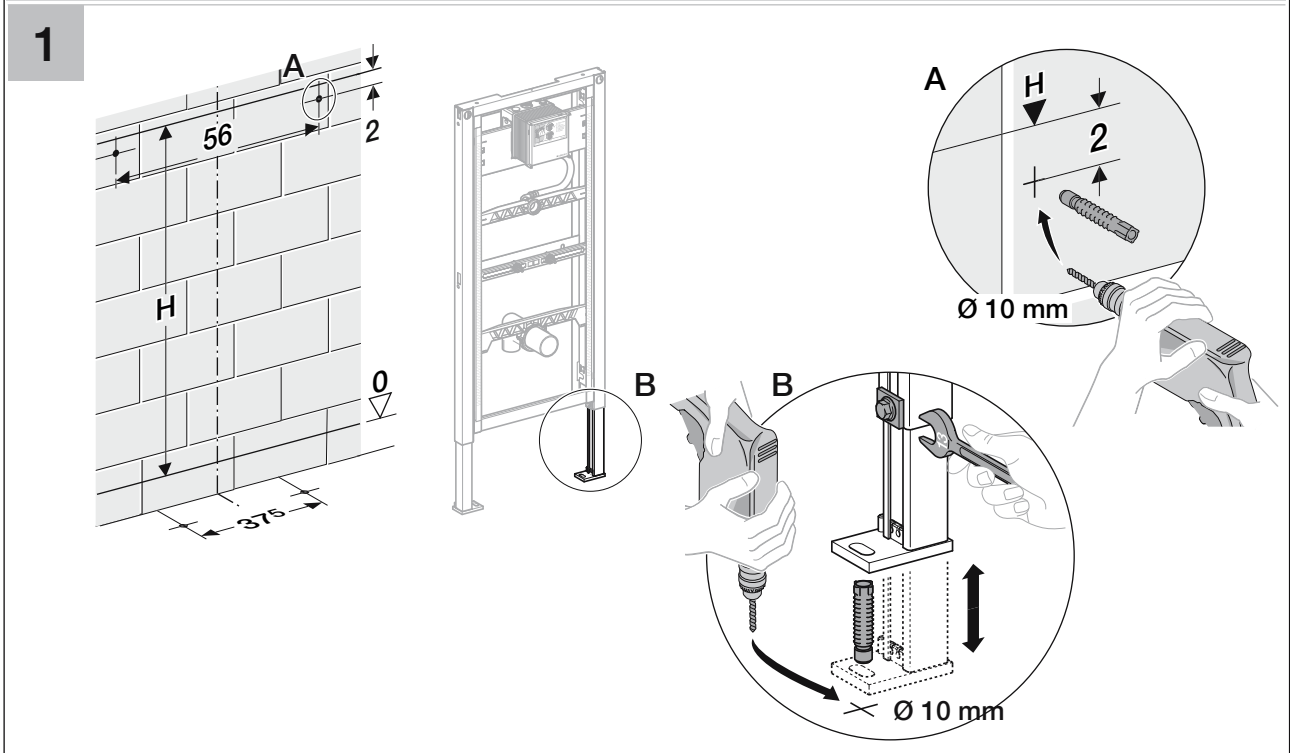
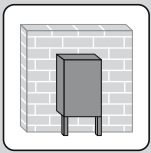
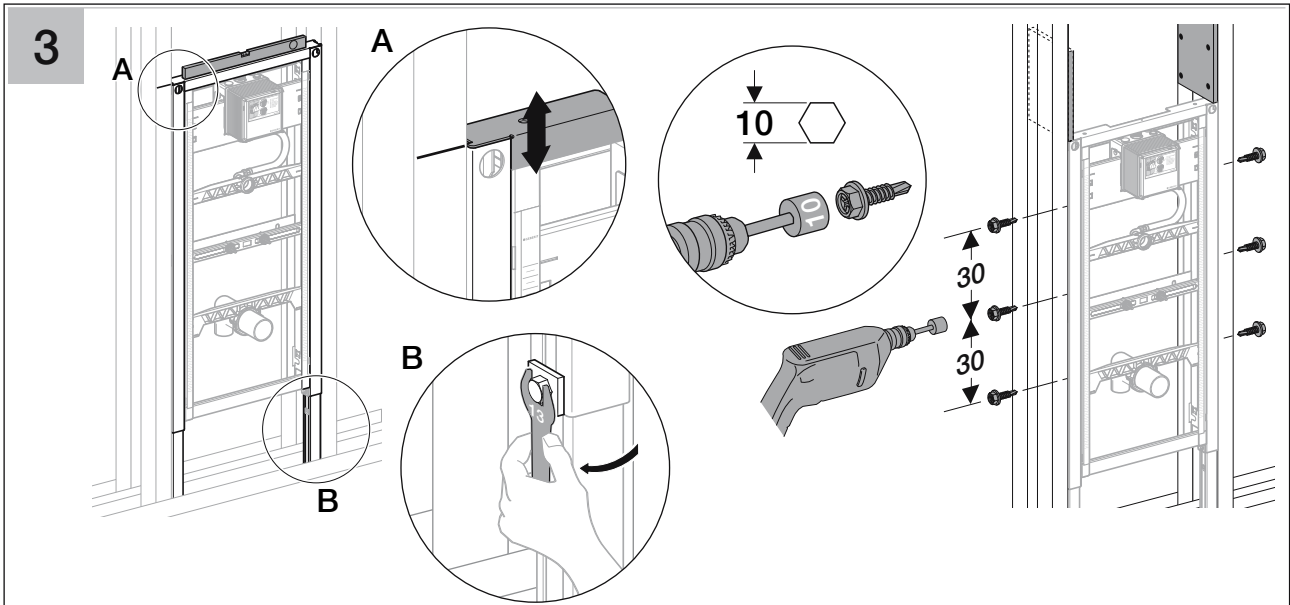

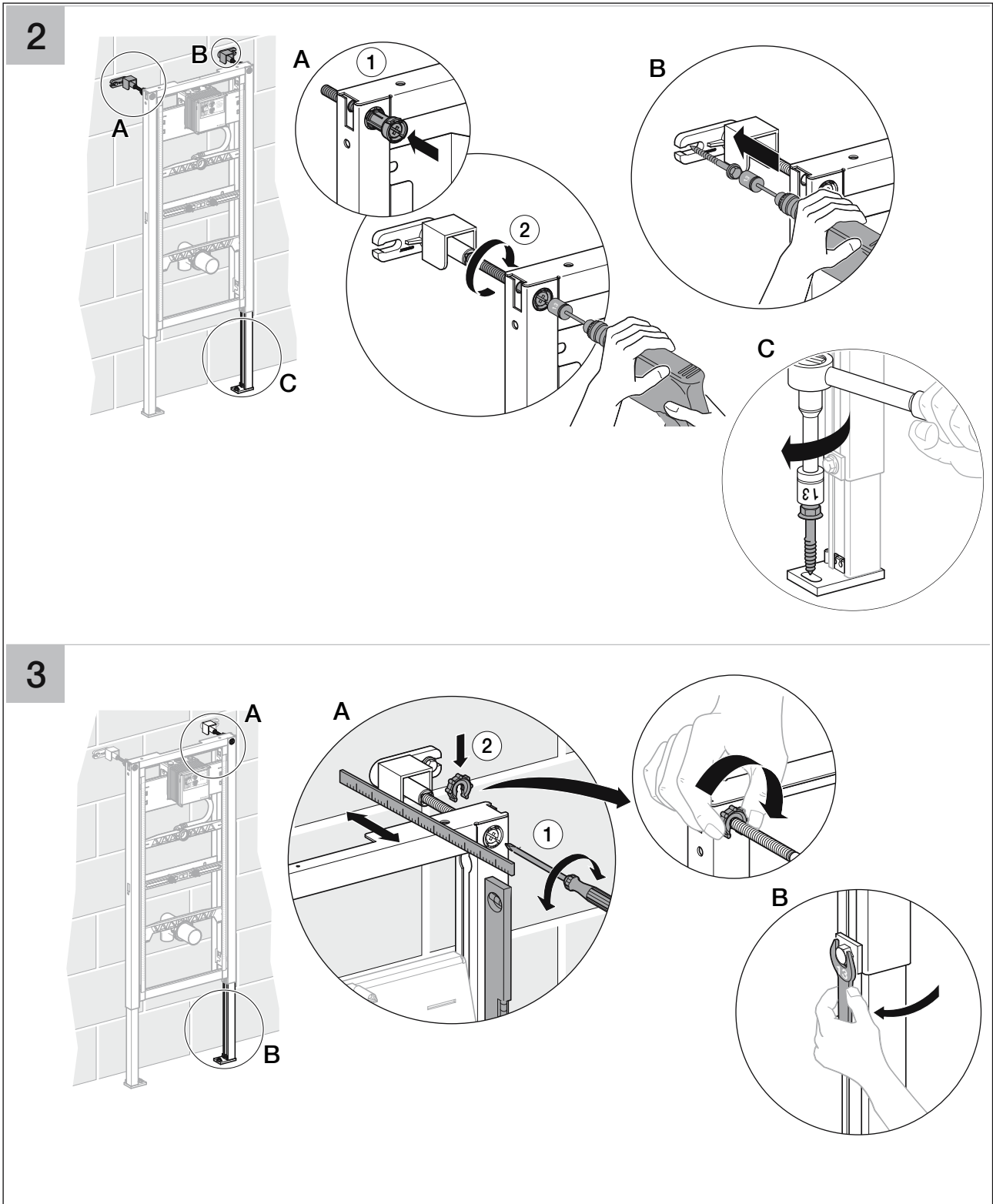

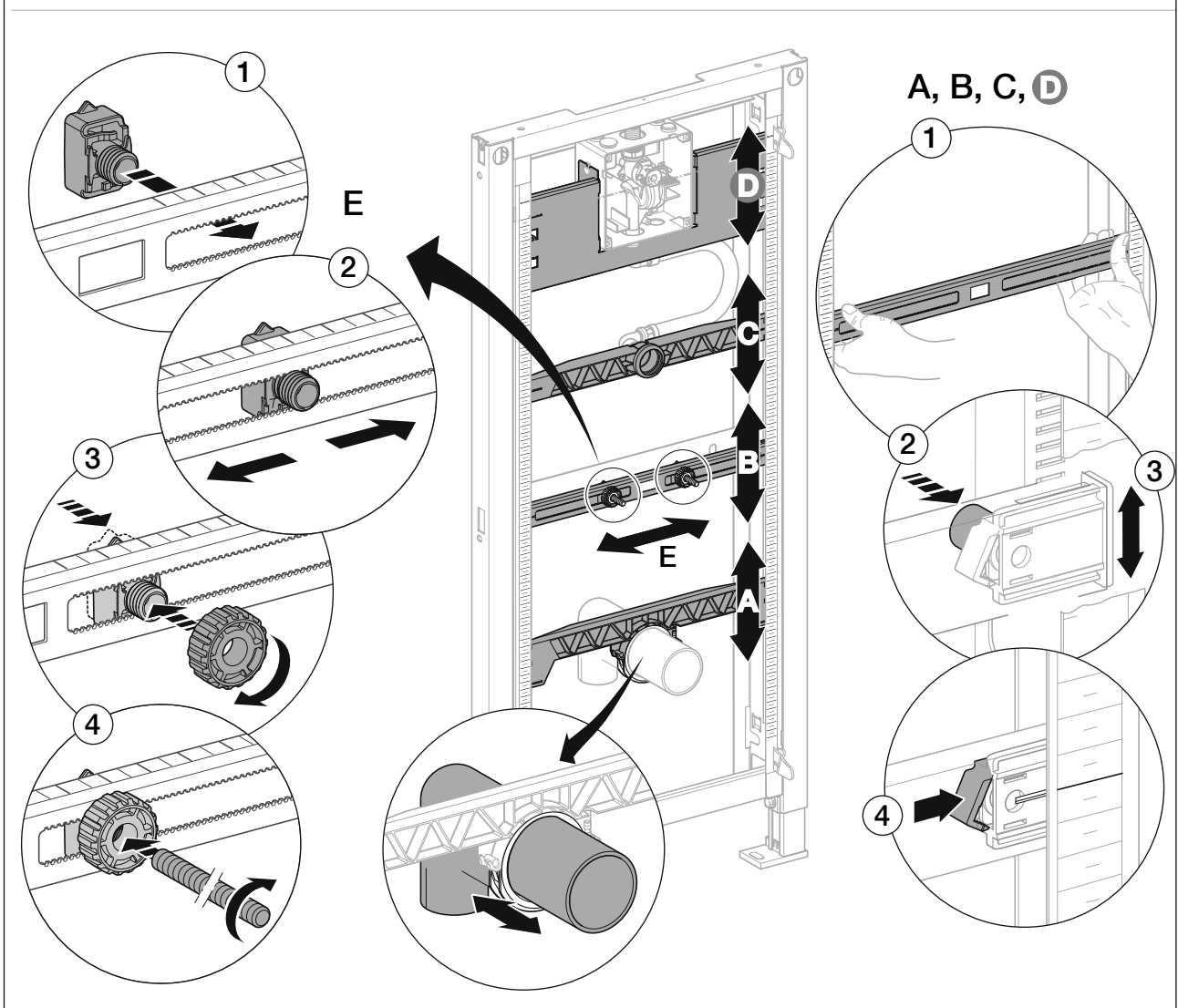
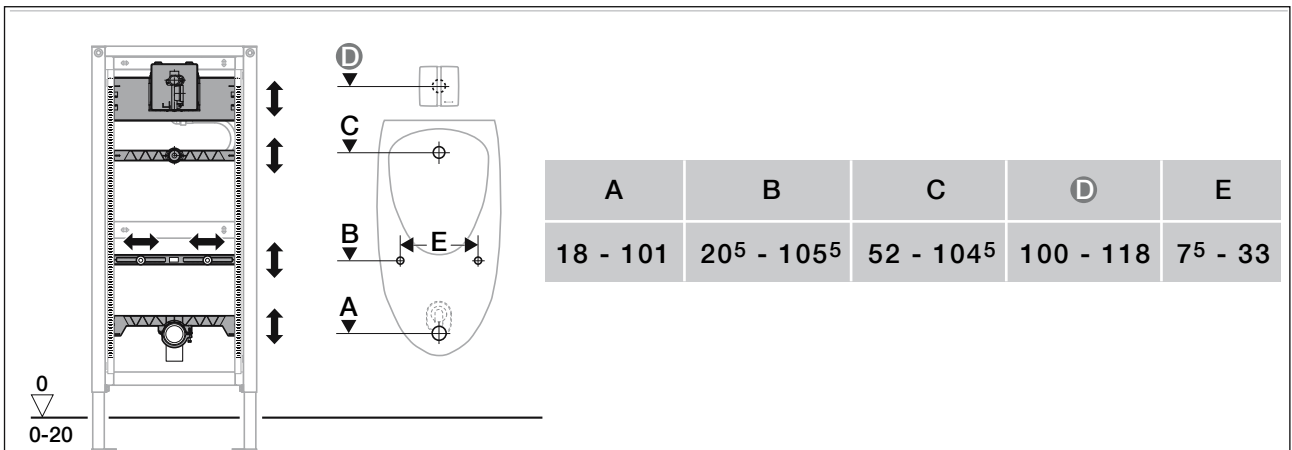

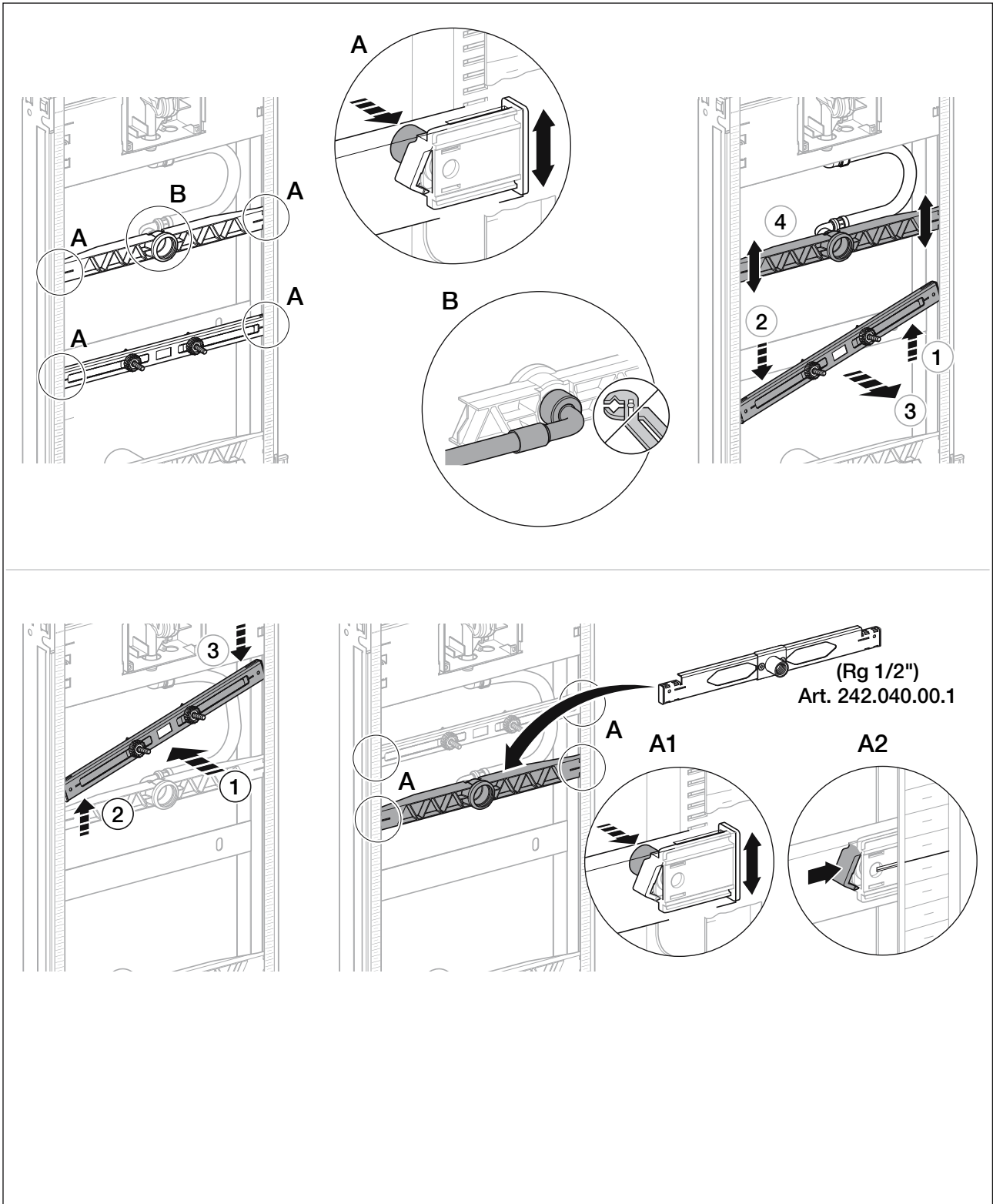



Vorschrift Allpoligen Hauptschalter mit mind. 3 mm Kontaktöffnung vorschalten.

Prescription An all-pole main switch with a contact opening of at least 3 mm must be connected in series.

Prescription Intercaler un interrupteur principal unipolaire séparant tous les pôles et ayant une ouverture de contact d'au moins 3 mm.

Prescrizione Collegare in serie l'interruttore principale onnipolare con min. 3 mm di apertura per il contatto.

Voorschrift Alpolige hoofdschakelaar met minimaal 3 mm contactopening in serie schakelen.

Es obligatorio Preconectar un interruptor principal omnipolar con apertura de contactos de al menos 3 mm.

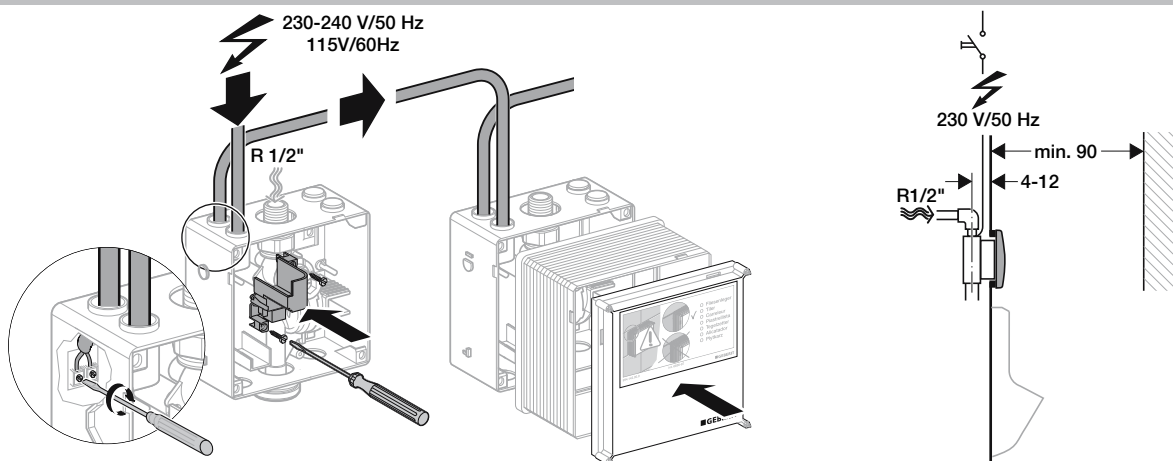

Betrieb mit Deckelurinal: Für den Betrieb mit Deckelurinal muss die Urinalsteuerung mit dem Geberit Service-Handy entsprechend konfiguriert werden.

Operation with a covered urinal: The urinal flushing system must be configured accordingly with the Geberit Service-Handy for operation with a covered urinal.

Mode avec urinoir à couvercle : Pour le mode avec un urinoir à couvercle, la commande d'urinoir doit être configurée de manière appropriée avec le Service-Handy de Geberit.

Funzionamento con orinatoio con coperchio: Per il funzionamento con orinatoio con coperchio i comandi dell'orinatoio dovranno essere appositamente configurati con il telecomando di assistenza Geberit (Service-Handy).

Spoeling voor urinoirs met deksel: Voor het gebruik van een urinoir met deksel moet de urinoirsturing met de Geberit Service-Handy geconfigureerd worden.

Operación con urinarios con tapa: Para el uso con urinarios con tapa el sistema electrónico de descarga requiere configuración correspondiente con el mando a distancia (Service-Handy).

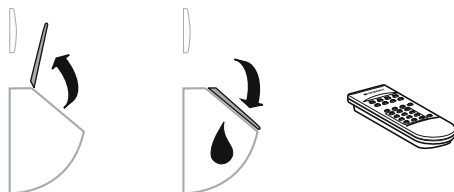

Geberit International AG
Schachenstrasse 77
CH-8645 Jona
www.geberit.com
dokumentation@geberit.com